

## Large Self-Assembled Organopalladium Spheres

Wilhelm T. S. Huck,<sup>†</sup> Frank C. J. M. van Veggel,<sup>†</sup>  
Boike L. Kropman,<sup>‡</sup> Dave H. A. Blank,<sup>‡</sup> Enrico G. Keim,<sup>§</sup>  
Mark M. A. Smithers,<sup>§</sup> and David N. Reinhoudt<sup>\*,†</sup>

Laboratory of Organic Chemistry and  
MESA Research Institute, University of Twente  
P.O. Box 217, 7500 AE, Enschede, The Netherlands  
Laboratory of Low-Temperature Physics  
Department of Technical Physics, and  
Center of Materials Research  
University of Twente, The Netherlands

Received May 1, 1995

There is an increasing interest in well-defined structures of submicron dimensions (nanotechnology) for the development of new materials with applications in, e.g., quantum electronics, photonics, and chemoselective sensing.<sup>1</sup> Nanophysical fabrication methods (nanolithography) which operate from the bulk "down" have reached their diffraction limits. Chemistry builds structures from the atom "up" and should in principle produce materials which perfectly fit size requirements. Dendrimers have the well-defined structure to meet the requirements for new materials. They are prepared by stepwise growth, which may be divergent<sup>2</sup> or convergent.<sup>3</sup> Until recently dendrimers were fully organic in nature,<sup>4</sup> but very recently also transition metal containing derivatives<sup>5,6</sup> and organometallic dendrimers were described by Puddephatt<sup>7</sup> and Balzani.<sup>8</sup>

Previous work in our group was directed toward the self-assembly of small aggregates (dimers) and coordination polymers using the uranyl cation.<sup>9</sup> In this communication we show the first example of spheres of well-defined dimensions with a narrow size distribution formed completely by self-assembly,<sup>10</sup> i.e., without the need of repeated chemical reactions. Our approach employs the combination of a kinetically inert tridentate ligand and kinetically labile cyano groups in a square planar Pd(II) complex. The self-assembly process is based on the substitution of the labile acetonitrile molecules for cyanomethyl groups of the tridentate ligand thereby adding a new building block, as is schematically depicted in Scheme 1. The branching in the repeating units leads to a metallo-dendritic structure.

Ligand precursor **1** (Scheme 2) was prepared in five steps from 5-hydroxyisophthalic acid,<sup>11</sup> and subsequently coupled with dibromide **2** to introduce a cyanomethyl ligand. The building block was prepared by refluxing **3** in CH<sub>3</sub>CN with Pd-

Scheme 1. Schematic Self-Assembly of a Second-Generation Metallo-dendrimer

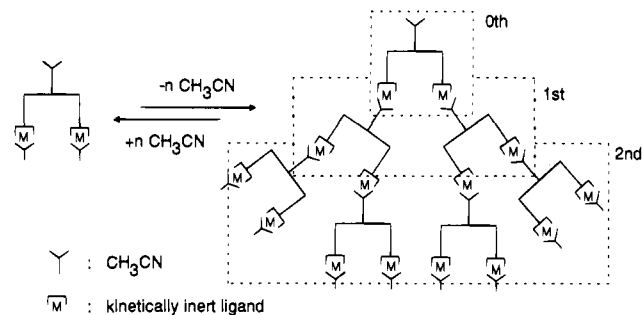

Scheme 2<sup>a</sup>

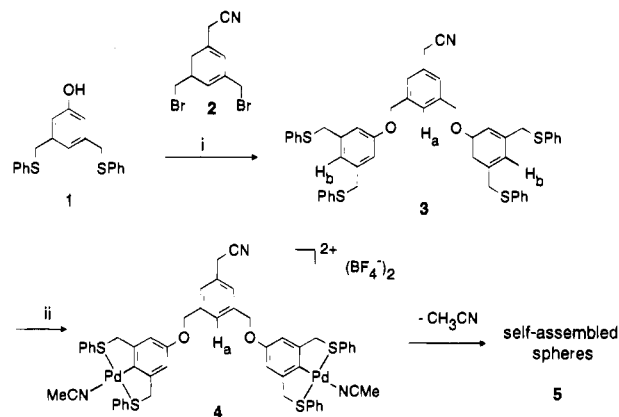

<sup>a</sup> (i) K<sub>2</sub>CO<sub>3</sub>, CH<sub>3</sub>CN; (ii) Pd[CH<sub>3</sub>CN]<sub>4</sub>(BF<sub>4</sub>)<sub>2</sub>, CH<sub>3</sub>CN.

[CH<sub>3</sub>CN]<sub>4</sub>(BF<sub>4</sub>)<sub>2</sub>.<sup>12</sup> This gives the square planar Pd(II) complex **4** in quantitative yield, with one acetonitrile molecule per Pd(II) center as a labile coordinating ligand.<sup>13</sup> The <sup>1</sup>H NMR spectrum in CD<sub>3</sub>CN shows a broad singlet for the CH<sub>2</sub>SR protons at δ 4.6 because of the conformational interconversion of the Pd(II)-containing five-membered rings.<sup>14</sup> In **4** the signal for the proton at δ 6.85 (H<sub>b</sub>) is absent, indicating complete cyclopalladation. No cyclopalladation had occurred at position H<sub>a</sub>, as is evident from the absorption at δ 7.41 (**3**: δ 7.37). FAB-MS (+VE) gave a peak at 1155.9 corresponding to the bis-palladium complex minus one BF<sub>4</sub><sup>-</sup> counteranion and one acetonitrile ligand.

When all solvent molecules, including acetonitrile, were removed from a solution of **4** in nitromethane by gentle heating *in vacuo*, the cyanomethyl group of the bis-palladated complex **4** replaced the acetonitrile at the fourth coordination site of palladium. This coordination of the cyanogroup can be monitored by FT-IR spectroscopy in a nitromethane solution and in the solid state (KBr disk), because of the characteristic shift (C≡N stretch) from 2250 cm<sup>-1</sup> (free cyanomethyl group) to 2290 cm<sup>-1</sup> upon coordination<sup>15</sup> (Figure 1).

(11) 5-Hydroxyisophthalic acid dimethyl ester was protected with TBDMSiCl, and the esters were reduced to the alcohols. Conversion into good leaving groups and subsequent coupling with thiophenol and removal of the TBDMS protective groups gave **1**.

(12) Loeb, S. J.; Shimizu, G. K. H. *J. Chem. Soc., Chem. Commun.* **1993**, 1395–1397.

(13) For **3**: <sup>1</sup>H NMR (250 MHz, CDCl<sub>3</sub>) δ 7.37 (s, 1H, Ar<sub>CN</sub>H), 7.31 (s, 2H, Ar<sub>CN</sub>H), 7.28–7.16 (m, 20H, SPh), 6.85 (s, 2H, Ar<sub>O</sub>H), 6.79 (s, 4H, Ar<sub>O</sub>H), 4.94 (s, 4H, CH<sub>2</sub>O), 4.03 (s, 8H, CH<sub>2</sub>S), 3.73 (s, 2H, CH<sub>2</sub>CN); FAB-MS (+VE) 817.8 (M)<sup>+</sup>, 708.6 (M - SPh)<sup>+</sup>, 598.6 (M - 2SPh)<sup>+</sup>. For **4**: <sup>1</sup>H NMR (250 MHz, CD<sub>3</sub>CN) δ 7.81 (m, 8H, SPh), 7.48 (m, 12H, SPh), 7.41 (s, 1H, Ar<sub>CN</sub>H), 7.36 (s, 2H, Ar<sub>CN</sub>H), 6.72 (s, 4H, Ar<sub>O</sub>H), 4.97 (s, 4H, CH<sub>2</sub>O), 4.6 (bs, 8H, CH<sub>2</sub>S), 3.81 (s, 2H, CH<sub>2</sub>CN). A similar spectrum was recorded in nitromethane and showed a signal at δ 2.05 (s, 6H, 2CH<sub>3</sub>CN); FAB-MS (+VE) 1155.9 (M - CH<sub>3</sub>CN/BF<sub>4</sub>)<sup>+</sup>.

(14) Canty, A. J.; Minchin, N. J. *J. Chem. Soc., Dalton Trans.* **1987**, 1477–1483.

<sup>†</sup> Laboratory of Organic Chemistry and MESA Research Institute.

<sup>‡</sup> Laboratory of Low-Temperature Physics, Department of Technical Physics.

<sup>§</sup> Center of Materials Research.

(1) Review: Ozin, G. *Adv. Mater.* **1992**, *4*, 612–648.

(2) Tomalia, D. A.; Naylor, A. M.; Goddard, W. A., III. *Angew. Chem., Int. Ed. Engl.* **1990**, *29*, 138–175.

(3) Hawker, C. J.; Fréchet, J. M. J. *J. Am. Chem. Soc.* **1990**, *112*, 7638–7642.

(4) Jansen, J. F. G. A.; de Brabander-van den Berg, E. M. M.; Meijer, E. W. *Science* **1994**, *266*, 1226–1229.

(5) Liao, Y. H.; Moss, J. R. *J. Chem. Soc., Chem. Commun.* **1993**, 1774–1777. Knapen, J. W. J.; van der Made, A. W.; de Wilde, J. C.; van Leeuwen, P. W. N. M.; Wijkens, P.; Grove, D. M.; van Koten, G. *Nature* **1994**, *372*, 659–662.

(6) Dandliker, P. J.; Diederich, F.; Gross, M.; Knobler, C. B.; Lonati, A.; Sanford, E. M. *Angew. Chem., Int. Ed. Engl.* **1994**, *33*, 1739–1742.

(7) Acher, S.; Puddephatt, R. J. *J. Chem. Soc., Chem. Commun.* **1994**, 1895–1896. Acher, S.; Puddephatt, R. J. *Angew. Chem., Int. Ed. Engl.* **1994**, *33*, 847–849.

(8) Serroni, S.; Denti, G.; Compagna, S.; Juris, A.; Ciano, M.; Balzani, V. *Angew. Chem., Int. Ed. Engl.* **1992**, *31*, 1493–1495.

(9) Rudkevich, D. M.; Verboom, W.; Brzozka, Z.; Palys, M. J.; Stauthamer, W. P. R. V.; van Hummel, G. J.; Franken, S. M.; Harkema, S.; Engbersen, J. E.; Reinhoudt, D. N. *J. Am. Chem. Soc.* **1994**, *116*, 4341–4351.

(10) Whitesides, G. M.; Simanek, E. E.; Mathias, J. P.; Seto, C. T.; Chin, D. N.; Mammen, M.; Gordon, D. M. *Acc. Chem. Res.* **1995**, *28*, 37–44.

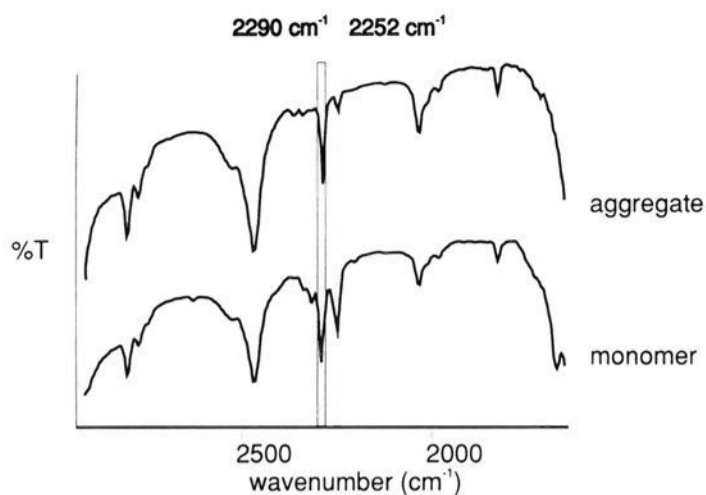

**Figure 1.** FT-IR spectrum of monomer and assembly in nitromethane solution.

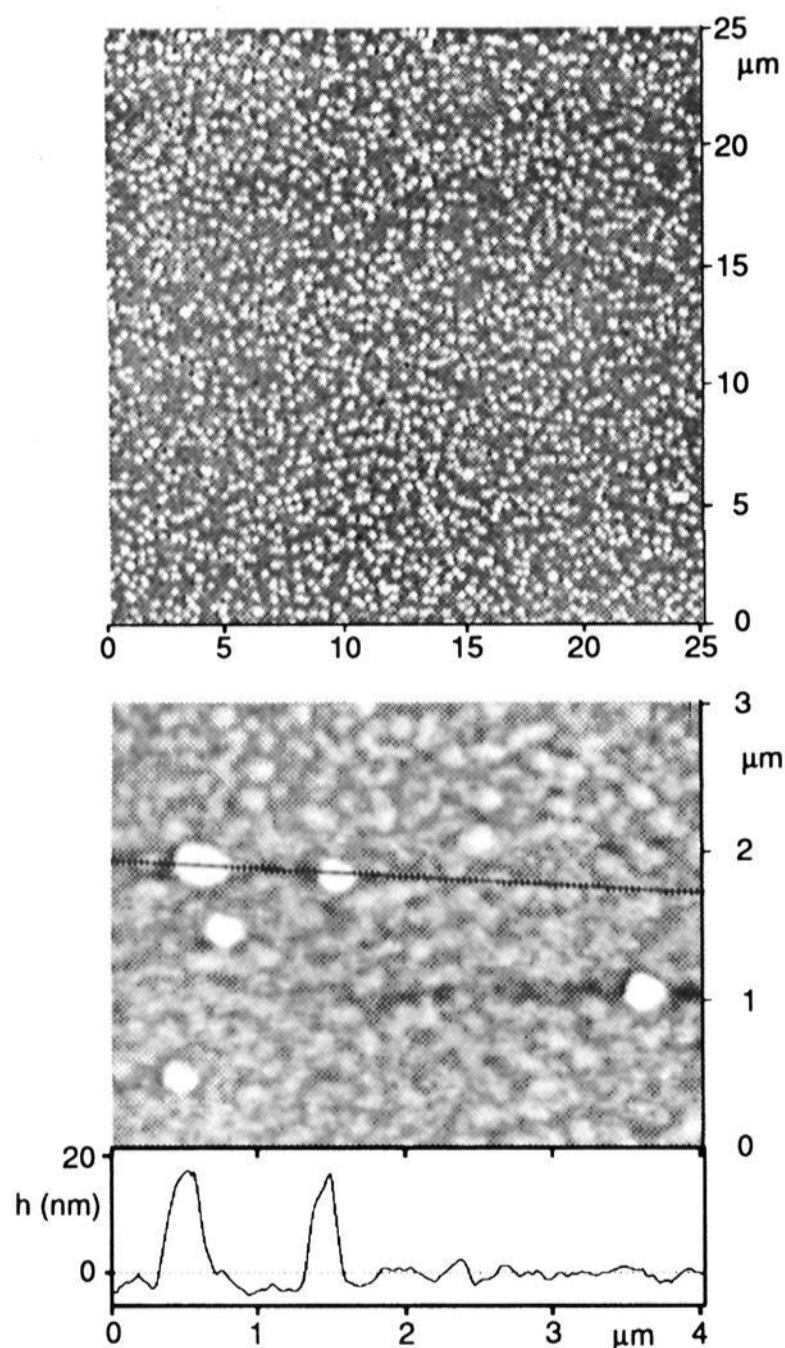

**Figure 2.** Top:  $25 \times 25 \mu\text{m}$  AFM scan of self-assembled spheres on a gold substrate. Middle: An enlargement of a representative  $3 \times 4 \mu\text{m}$  area shows some isolated spheres (white dots). Bottom: A line scan over two of the aggregates. The gray scale is 40 nm.

The  $^1\text{H}$  NMR spectrum in  $\text{CD}_3\text{NO}_2$  of the acetonitrile-free compound **4** shows very broad signals, indicating association in solution. When small amounts of acetonitrile were added to this solution, all signals became sharp.<sup>16</sup> This proves that the self-assembly of **4** and disassembly of **5** is a completely reversible process. QELS (quasi-elastic light scattering) measurements of nitromethane solutions showed particles with a modal hydrodynamic diameter of 200 nm.<sup>17</sup>

The size of the aggregates was measured by atomic force microscopy (AFM),<sup>18</sup> after evaporation of the nitromethane

(15) Storhoff, B. N.; Lewis, H. C. *Coord. Chem. Rev.* **1977**, *23*, 1–23.

(16) The original broad spectrum can be restored when the solution is evaporated completely and redissolved in acetonitrile-free nitromethane.

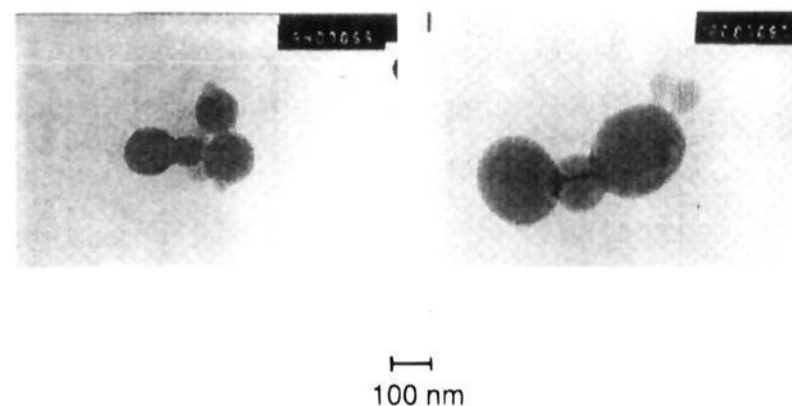
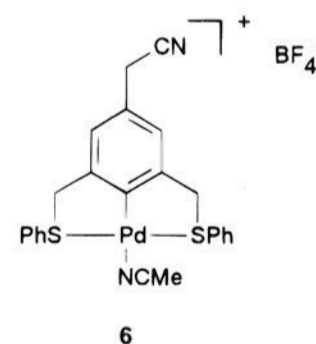

**Figure 3.** TEM images of self-assembled structures.

solution on a gold surface. A representative part of the surface is shown in Figure 2. The globular-shaped assemblies are clearly visible on a relatively rough gold substrate. The average diameter of these aggregates, as found by the grain size analysis routine of the instrument's software, is 205 nm, with a relatively narrow distribution: 80% (95%) of the diameters are found within  $\sigma_d$  ( $2\sigma_d$ ) of the mean value. Grazing-angle FT-IR on a glass surface covered with the spheres showed the characteristic gold  $\text{C}\equiv\text{N}$  signal of coordinated cyano groups at  $2290 \text{ cm}^{-1}$ . When a glass substrate was used instead of gold, the same spheres were observed, of roughly the same size. This indicates that the interaction of the spheres with the surface does not significantly influence their size.

Samples for transmission electron microscopy (TEM) were prepared by slow evaporation of a nitromethane solution on a carbon-coated copper grid. Figure 3 clearly shows globular aggregates in the 150–200 nm range. This is in good agreement with the diameter measured with AFM and indicates that Pd is present throughout the spherical assembly.<sup>19</sup> Energy dispersive X-ray spectrometry (EDX) revealed the presence of the elements Pd and S in these aggregates, proving that these structures are not artifacts.

The nonbranched Pd(II) complex **6** was treated according to the same procedure, but TEM measurements did not show globular structures. This supports our concept, in which branching is essential.



In conclusion we can state that, by proper design of a branched repeating unit, large spheres with well-defined dimensions can be formed by self-assembly, although we have no direct evidence for branching. We have shown self-assembly to occur not only in the solid state but also in solution. Structural factors that determine the size of these structures are under investigation.

We thank the Dutch Foundation for Chemical Research (SON) for financial support and Dr. J. Lichtenbelt at Akzo-Nobel Laboratories (Arnhem, The Netherlands) for the light-scattering experiments.

JA951402N

(17) GPC in nitromethane showed different not well-separated fractions, but these could not be related to a reference molecular weight because of insolubility of the linear polystyrene standards.

(18) The instrument used is a Nanoscope III operating in constant force ( $\sim 50 \text{ nN}$ ) mode with cantilever force constants of  $0.58 \text{ N/m}$  and a homemade supertip.

(19) Alkyl chains can be seen with AFM/STM, but not with TEM, which can result in significantly different diameters when measuring surfactant-coated metal colloids with TEM and STM. Reetz, M. T.; Helbig, W.; Quaiser, S. A.; Stimming, U.; Vogel, R. *Science* **1995**, *267*, 367–370.